

**Total Market:**

- 18 million car enthusiasts as of 2021
- 664,000 Mechanics in the U.S.
- 18% of the car owning population change their own oil

Currently targeting 18 million car enthusiasts with a 1% capture (186,640) of this market

**Sales Forecast:**  
 Year 1 – \$1,177,469  
 Year 2 – \$1,412,963  
 Year 3 – \$1,766,204

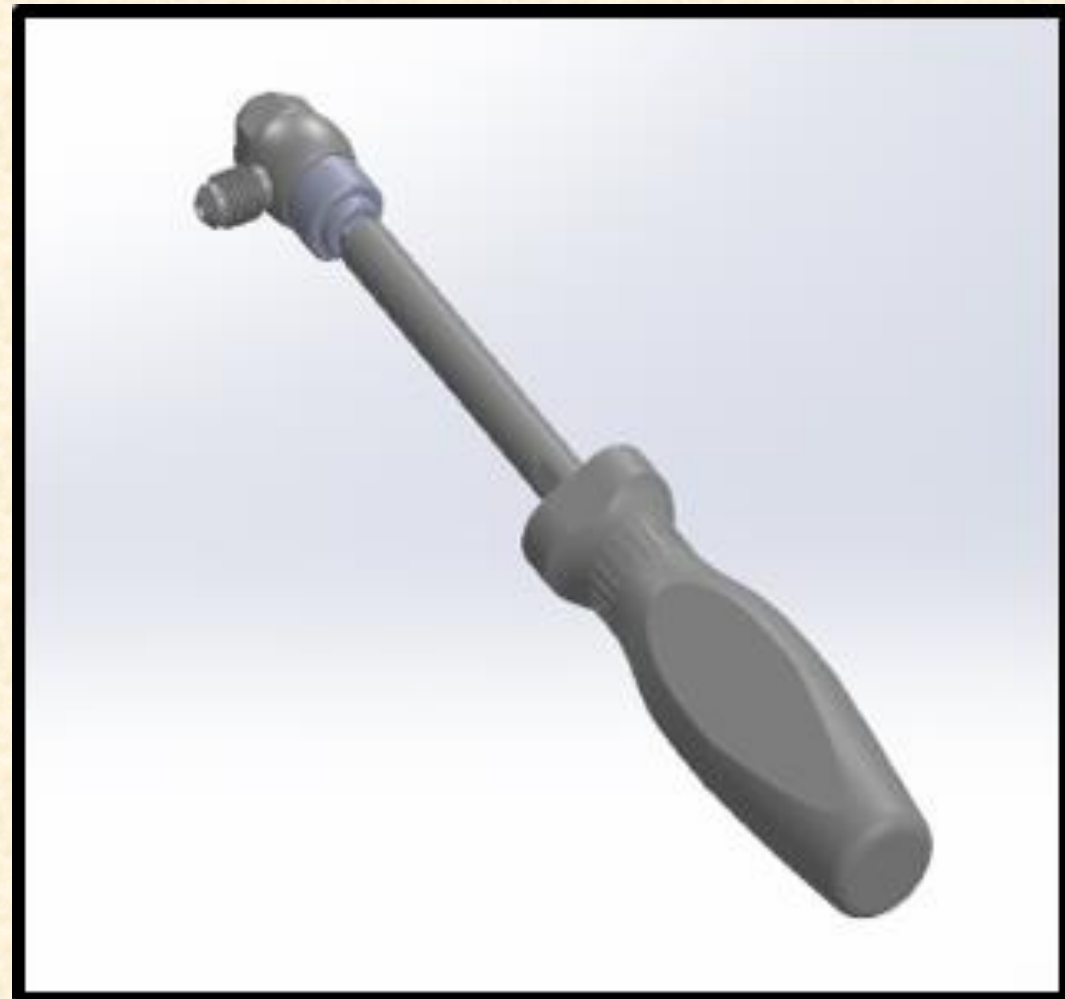
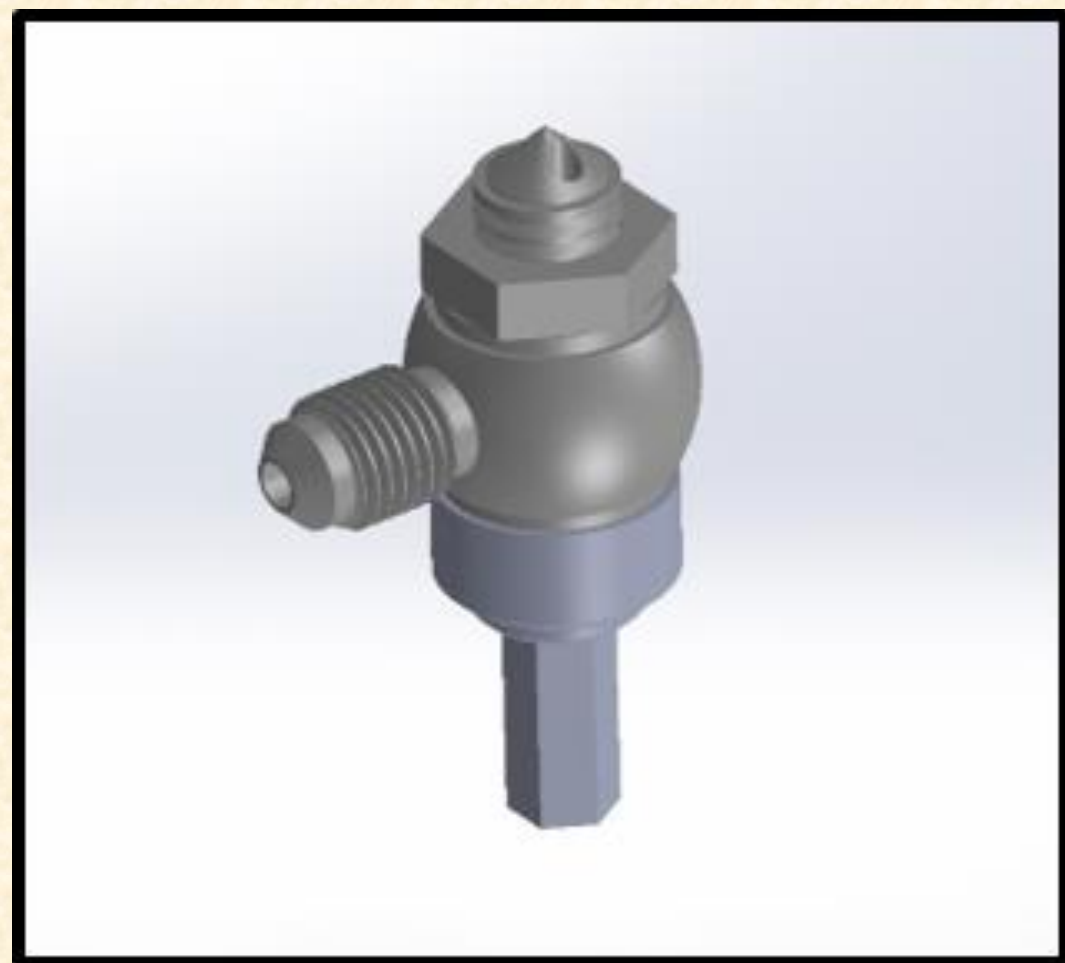

**Value Proposition:**  
 No Drip can eliminate oil change spills while providing a clean experience for customers with a safe disposal for the environment

**Why No Drip?**

- Practical
- Easy to use
- Safe
- Clean
- Universal
- Eco-Friendly
- High Quality

**MSRP:**  
**\$39.99**

**Tired of this Mess?  
 Let us do the rest!**



*The No Drip oil change assistance device is capable of draining any universal spin-on oil filter, while also maintaining a spill free environment for optimal results.*



Feature	Function	Benefits
Threaded Tap/Puncture Tool	The ability to puncture an oil filter to create a leak free seal by compressing the O-ring against the oil filter.	Retention of oil before removing oil filter.
Universal Tool Adaptability	Ability to attach our tool to a universal screwdriver	Ability to reach more tight spots within an engine bay.
Small Design	The ability to maneuver our tool in tight to reach places	<ul style="list-style-type: none"> <li>• Simplicity</li> <li>• Ease of use</li> <li>• Safety</li> </ul>
Durability	Withstand impact of piercing aluminum shell of oil filter	Withstand a shelf life of 3-5 years.